

Metro Lounger

8-04

Assembly Instructions

© 2004 Norka Mfg., Inc.

Hardware

Please inspect your hardware kit prior to assembly. If you do not have the indicated number of hardware pieces, please notify the local retailer you purchased the frame from for replacements.

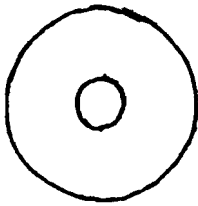

Large Washers
(10)

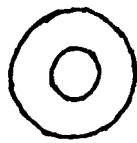

Small Washers
(8)



Barrel Nuts
(2)



Lock Nuts
(8)

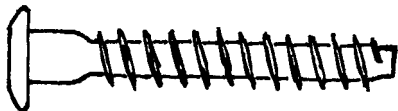

Long Wood Screws (16)

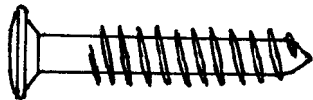

Short Wood Screws (12)



40 mm bolts (2)

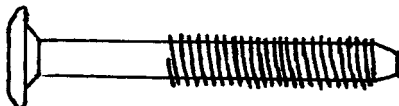

50 mm bolts (2)

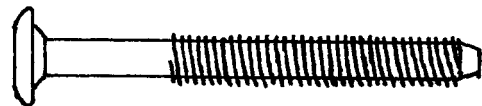

60 mm bolts (4)

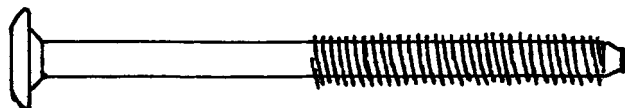

80 mm bolts (2)

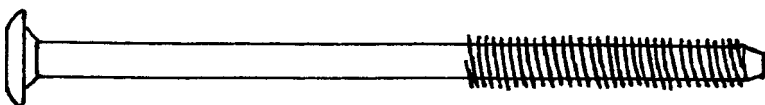

100 mm bolts (2)

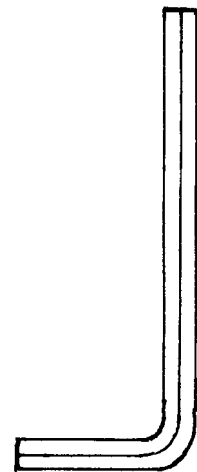

Alen Wrench (1)

Parts

Identify your frame parts. At this point it is best to organize your parts into three piles (one for “foot” pieces, one for “seat” pieces, and one for “back” pieces. Since the back and seat decks will be pre-assembled prior to final assembly this will eliminate the need to compare pieces to one another for size once assembly has begun.

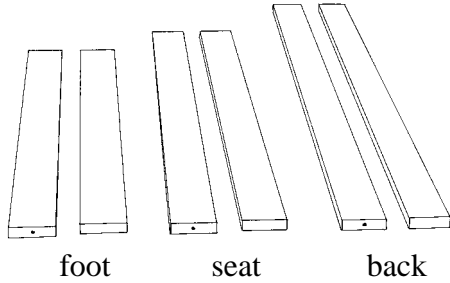

SLATS:

Foot slats (5) Twin, (8) Full, (9) Queen are the shortest of the three.
 Seat slats (6) Twin, (8) Full, (9) Queen are the middle size.
 Back slats (5) Twin, (8) Full, (9) Queen are the longest of the three.
Note that two of each kind of slat has a hole in each end.

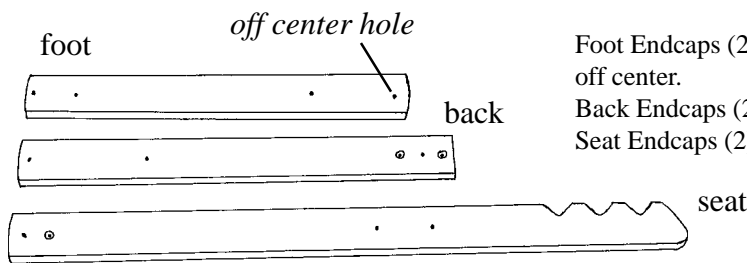

ENDCAPS:

Foot Endcaps (2) are the shortest of the three and have one hole slightly off center.
 Back Endcaps (2) are the longest of the two unnotched endcaps.
 Seat Endcaps (2) are very long and have three notches in the back.

RAILS:

Rails are long pieces with pockets routed into their faces. You will need to divide them into seat, back and foot rail sets as described below:

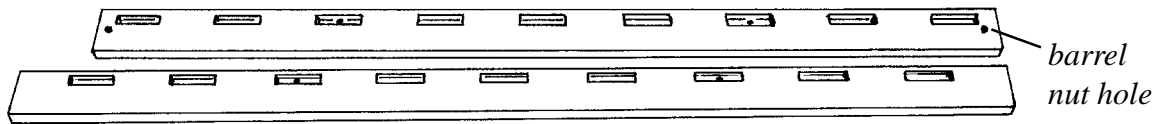

Seat Rails (2) are comprised of the longest single rail and the shortest single rail.

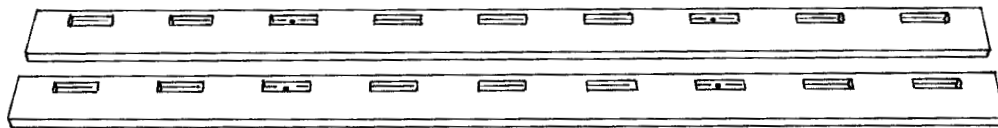

Back Rails (2) are the longest matched set of rails.

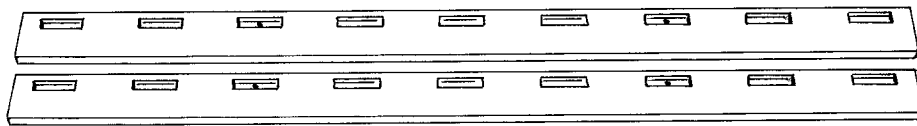

Foot Rails (2) are the shortest matched set of rails.

CONNECTING RAILS: (1 foot and 1 back)

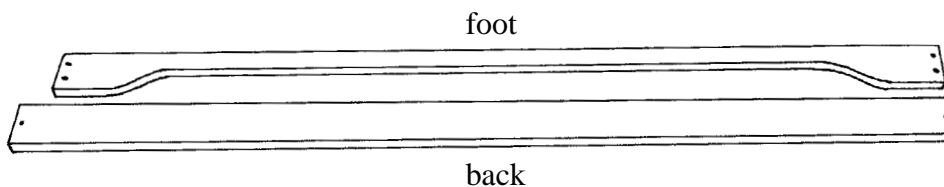

PROPS:
(2 each)

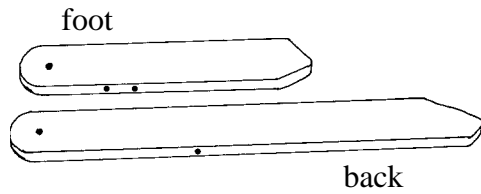

FEET:

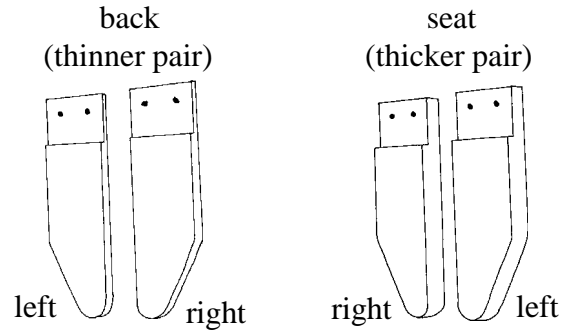

Assemble the Props

Assemble the Back Prop Assembly and the Foot Prop Assembly using long wood screws as shown.

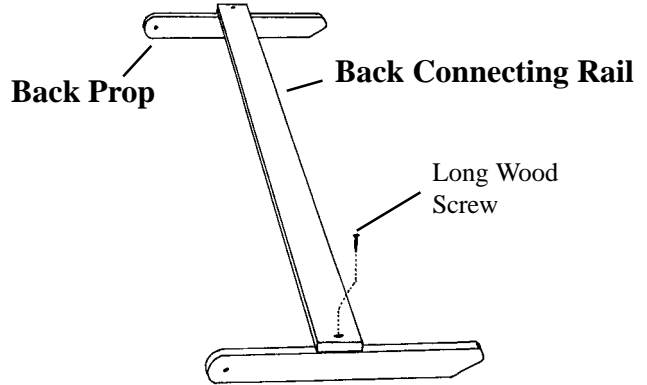
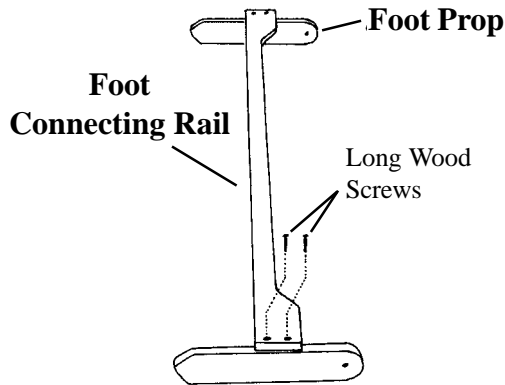

Assemble the Back Deck

Attach the **Back Rails** to a **Back Endcap** as shown using two **Long Wood Screws**, leaving both screws loose about 1/2 turn. Carefully insert **Back Slats** into the pockets making sure to install slats with **end holes** into the third pocket from each end on a full or queen frame (second pocket from each end on a twin frame). Attach the opposite **Back Endcap** like the first and tighten all screws tightly. Finally, insert **Short Wood Screws** in both holes of the **Back Rail** faces and tighten.

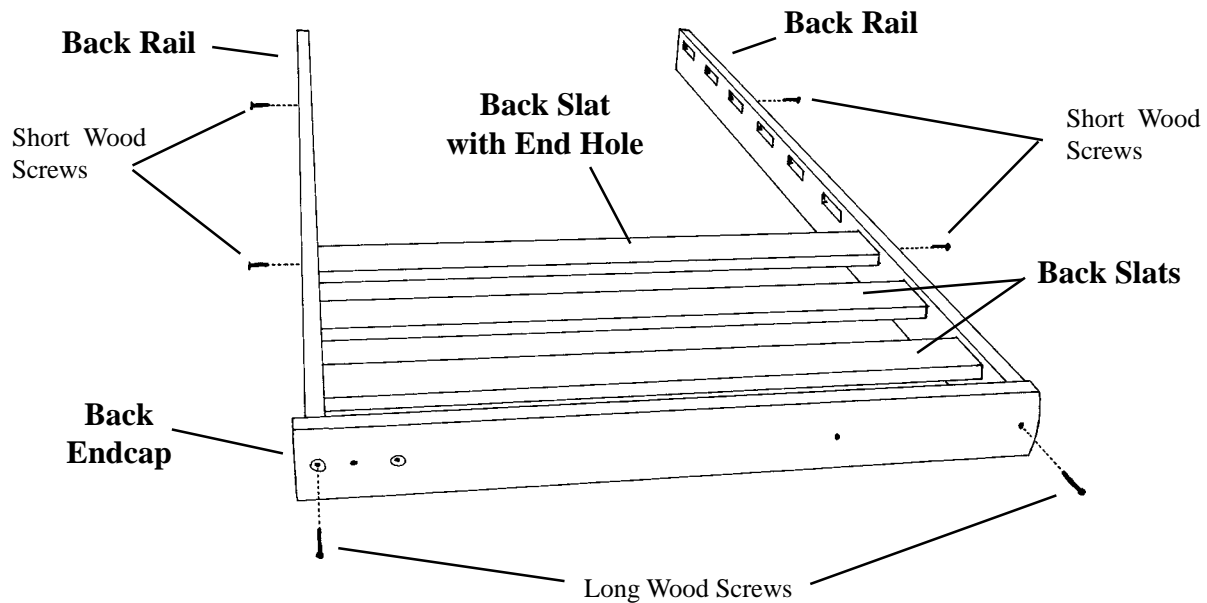

Finish the Back Deck

Attach one **Back Left Foot** to the **Back Deck** using a **50mm Bolt**, **Small Washer**, and **Lock Nut** as shown through the rearmost of the three holes ONLY. Make sure the step cut into the foot rests underneath the Back Endcap. Repeat this on the other side using a **Back Right Foot**.

Install the **Prop Assembly** as shown using a **60mm Bolt**, **Large Washer**, **Small Washer** and **Lock Nut** as shown.

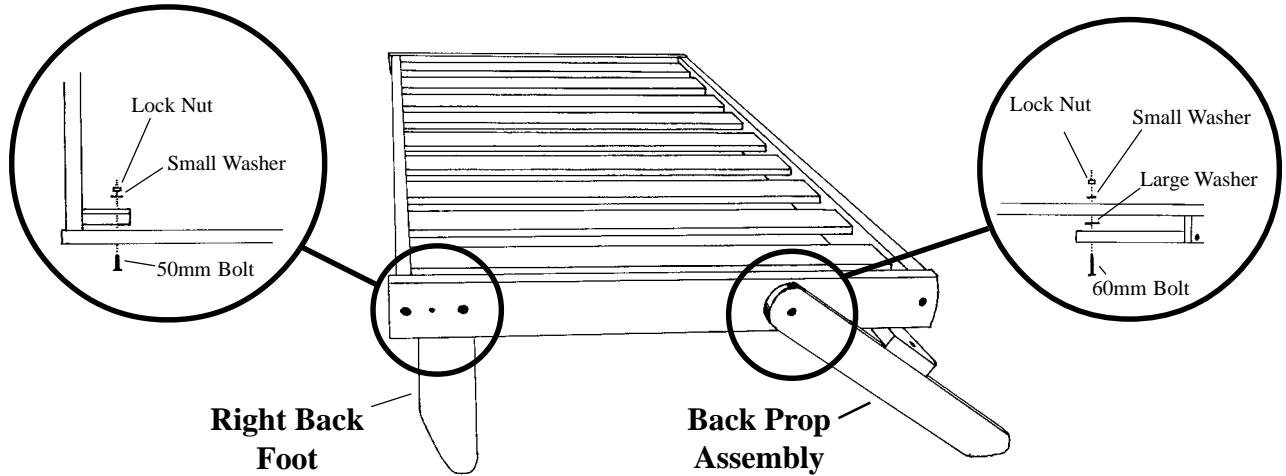

Assemble the Foot Extension

Attach the **Foot Rails** to a **Foot Endcap** as shown (making sure that the off center hole is pointing downward as illustrated) using two **Long Wood Screws**, leaving both screws loose about 1/2 turn. Carefully insert **Foot Slats** into the pockets making sure to install slats with **end holes** into the third pocket from each end on a full or queen frame (second pocket from each end on a twin frame). Attach the opposite **Foot Endcap** like the first and tighten all screws tightly. Finally, insert **Short Wood Screws** in both holes of the **Foot Rail** faces and tighten.

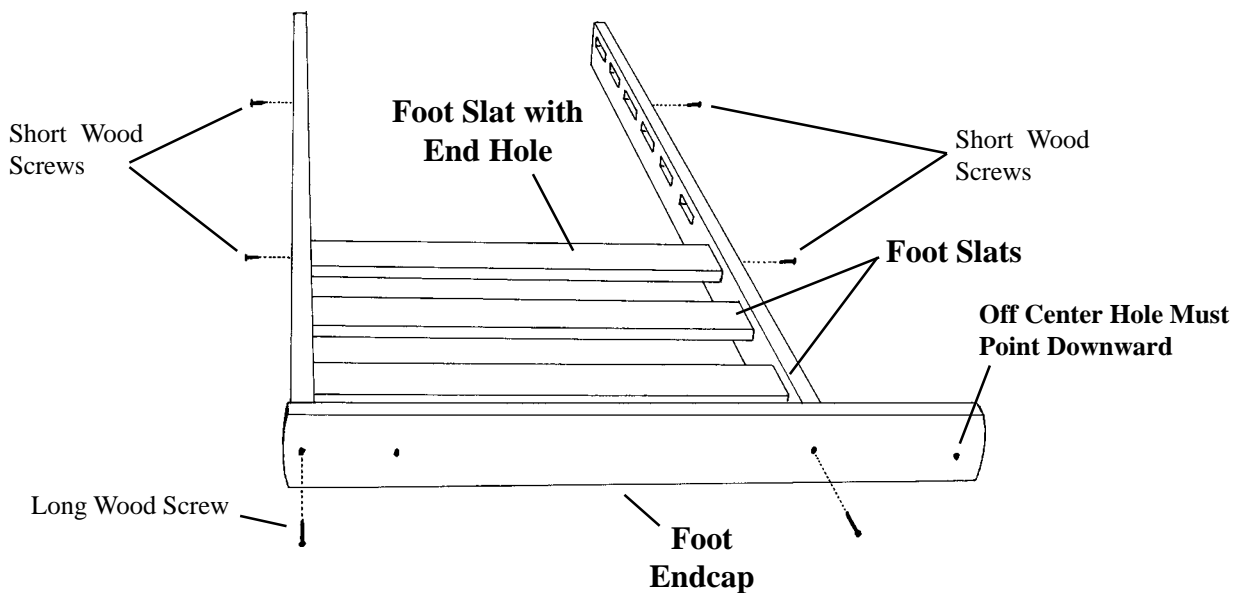

Attach the Foot Prop Assembly

Attach the Foot Prop Assembly to the Foot Extension as shown.

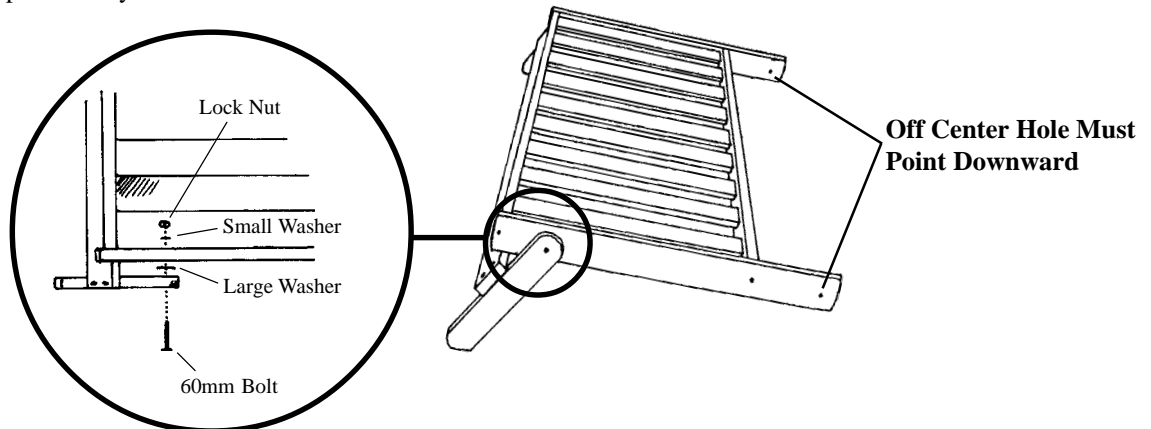

Attach the Seat Feet

Use 2 **40mm bolts** to attach the **Left and Right Seat Feet** to the **Seat Endcaps** through the threaded inserts in the rearmost hole as shown.

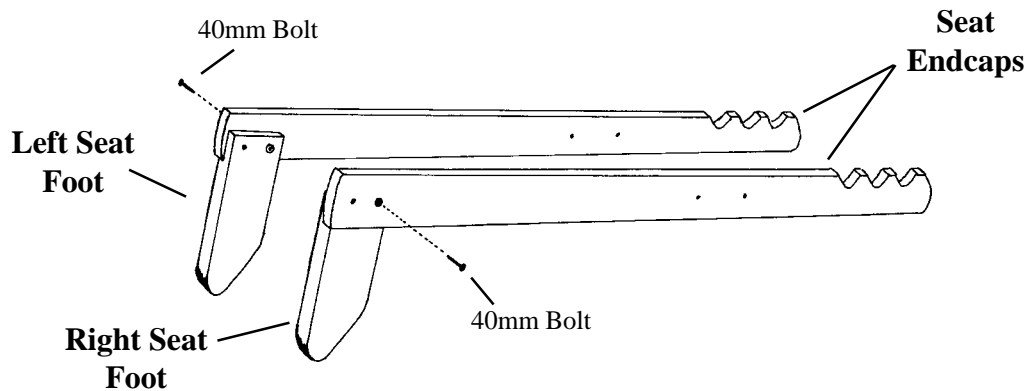

Seat Deck First Step

Attach the **Seat Endcap** assemblies to the **Foot Extension** and the **shorter Seat Rail** as shown.

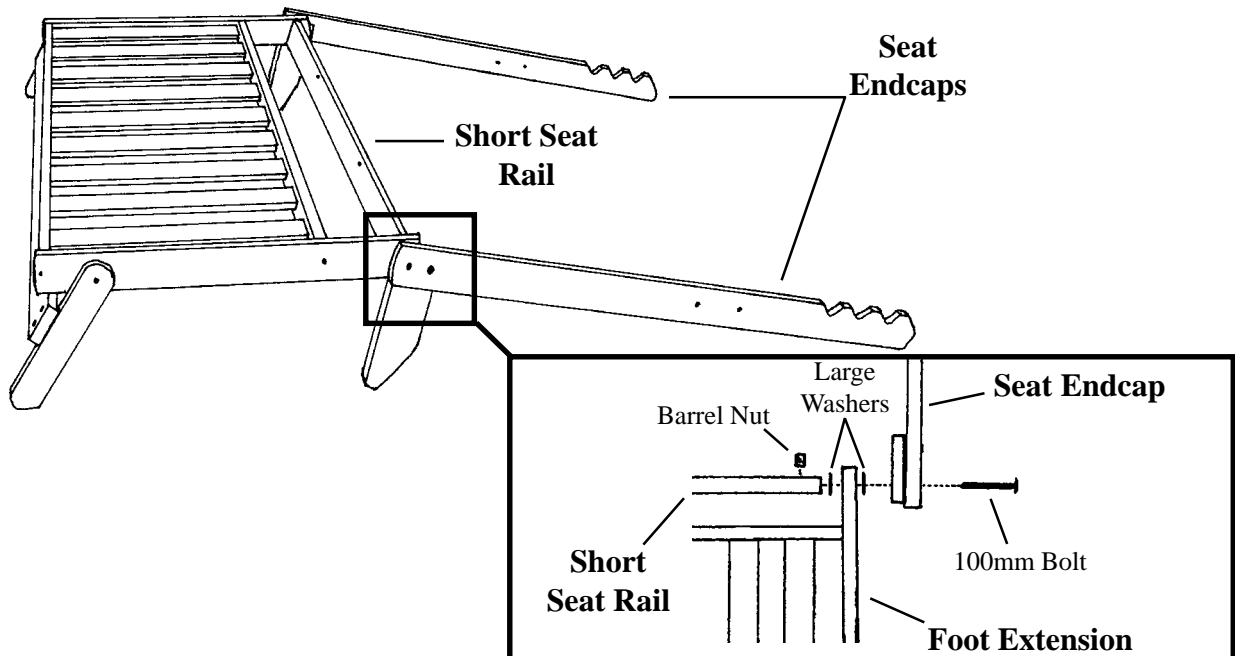

Seat Deck Final Assembly

Attach the **longer Seat Rail** to a **Seat Endcap** as shown using a **Long Wood Screw**, leaving that screw loose about 1/2 turn. Carefully insert **Seat Slats** into the pockets making sure to install slats with **end holes** into the third pocket from each end on a full or queen frame (second pocket from each end on a twin frame). Attach the opposite **Seat Endcap** like the first and tighten all screws tightly. Finally, insert **Short Wood Screws** in both holes of the **Seat Rail** faces and tighten.

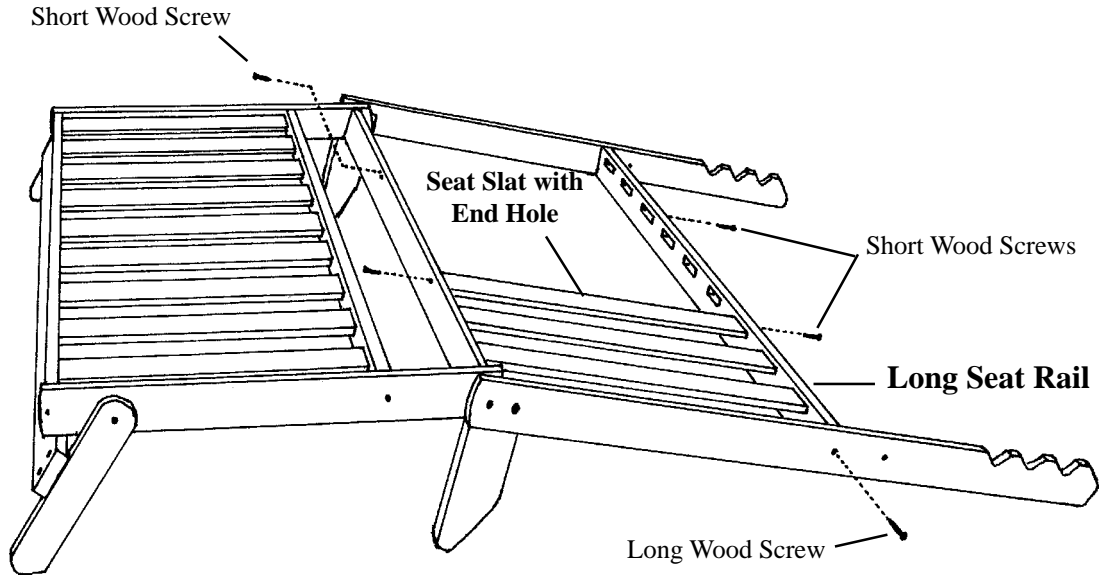

Seat Deck Final Assembly

Attach the **Back Deck** to the **Seat Deck** as shown. Before using your frame, make sure the feet have been installed properly so that the turned edges face each other as shown in the illustration.

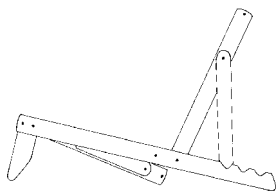
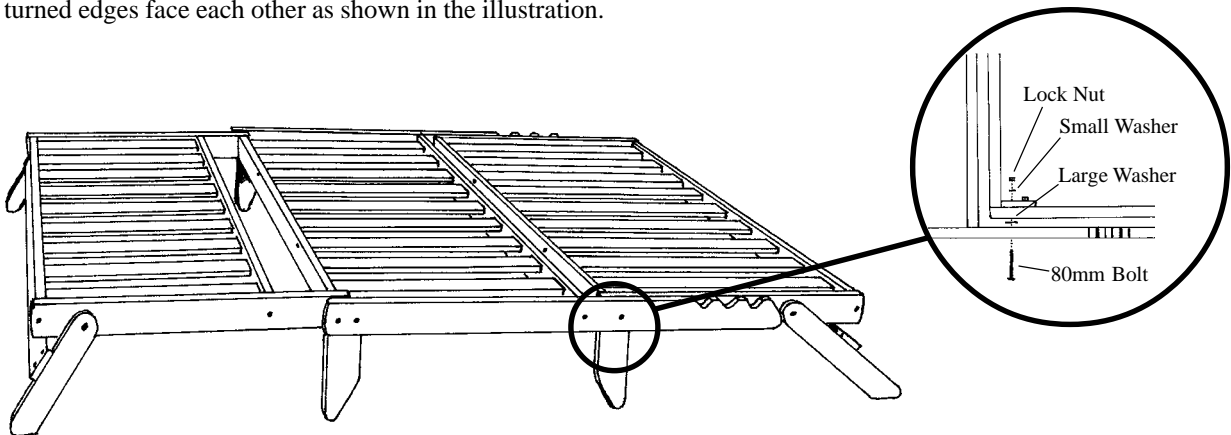

Chair

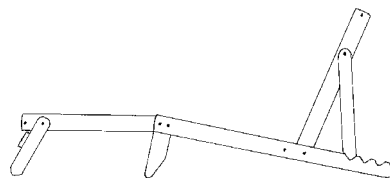

Hi Foot Lounger

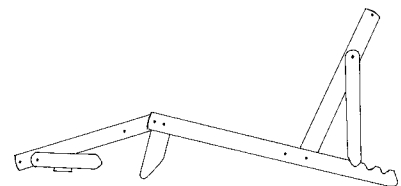

Low Foot Lounger



Bed

Norka Woodworks
143 W. Market St.
Akron, OH 44303